

## Making an Inlay Fan

An inlay fan is a traditional decorative effect – known as Marquetry – and used in the manufacture of furniture. They are straight forward to make and require only a few simple tools/equipment.

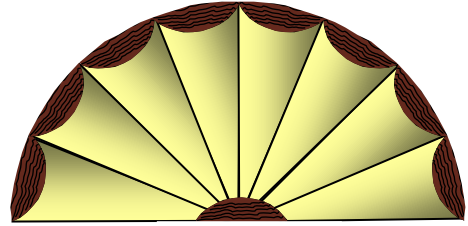

### Tools & Equipment

Stanley knife, scalpel or kraft knife, veneer saw, gouges, mallet, dividers (compasses), templates, ruler, straight edge, protractor (optional) and a source of heat.

### Materials

A selection of contrasting veneers, glue veneer tape, paper or thin card, cutting board, fine sand and a suitable tray.

### Suitable veneers

Satinwood, Holly, Box, Maple, Sycamore and Ash; Ebony, Rosewood, Walnut and Harewood.

### Step by Step Guide

1. Decide on the size of the fan required – in this activity our fan will be a semi-circle with a diameter of 130mm. Divide half of the semi circle into four using a protractor, dividers or compasses. The angle should be 22.5°.

**Note:** We only need to mark out quarter of a circle as shown

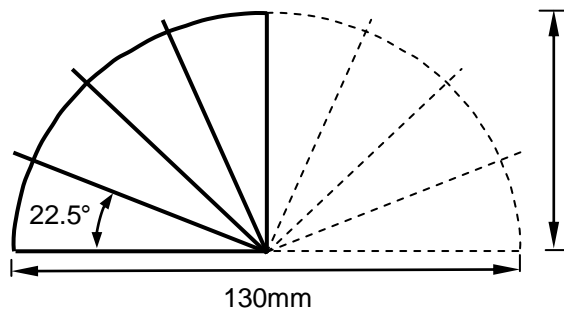

2. We now need to make a sector of the quarter circle into a triangle to help us mark them out on the veneer. Our triangle will have a base of 30mm and a height of 75mm – a little bit longer than we need to allow us to trim to size.

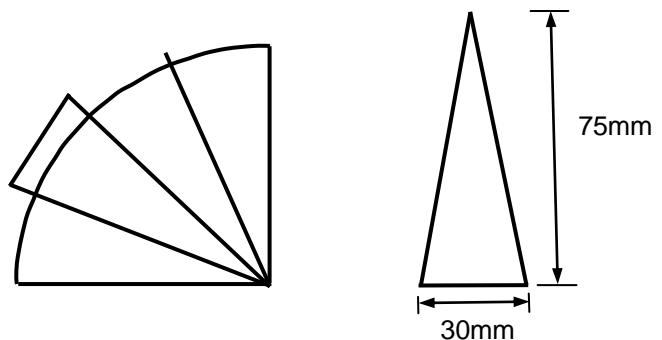

3. Select an appropriate veneer and begin to mark out the triangles.  
 Draw two parallel lines 75mm apart and a line at 90° to these.  
 On the top line measure in 30mm and on the bottom line measure in 15mm.  
 Join the marks up to form a triangle. Now mark 30mm from each point until you have 8 pieces.

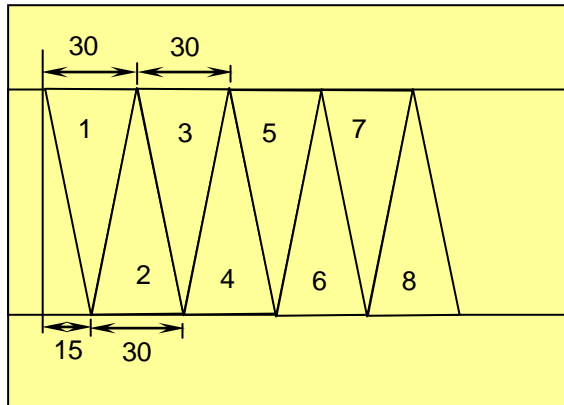

4. Taking great care, for safety and accuracy, cut the triangles out using a straight edge and sharp knife.

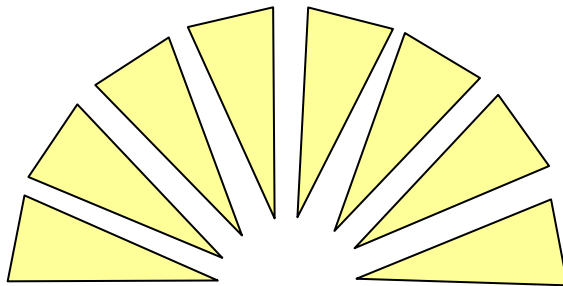

5. Again taking great care for safety reasons, place the veneer triangles into the tray of hot sand. This process will lightly scorch the wood and help give your fan a 3D look.

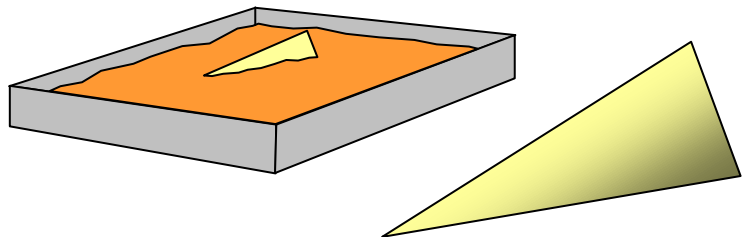

**Note:** Do not let the veneer touch the base of the tray and make regular checks so they do not burn too much.

6. Join your triangles together using gummed veneer tape (some makers use glue on the edges). Ensure all of the shading is positioned in the same direction for best effect (here on the right hand side).  
 Using a template mark the size of the finished semi-circle onto your fan with a pencil.

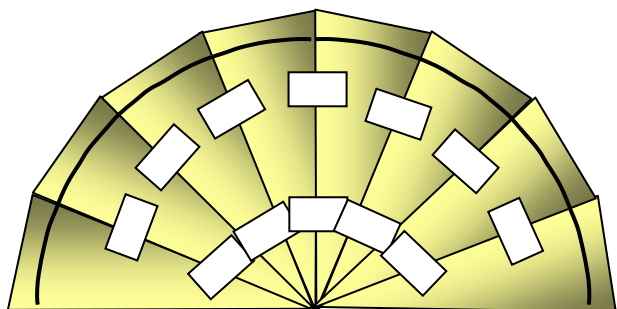

7. Using a gouge and a mallet carefully chop out scoops at the base of your triangles.

**Health & Safety:** Beware of the sharp edge on the gouge and wear safety goggles to protect eyes.

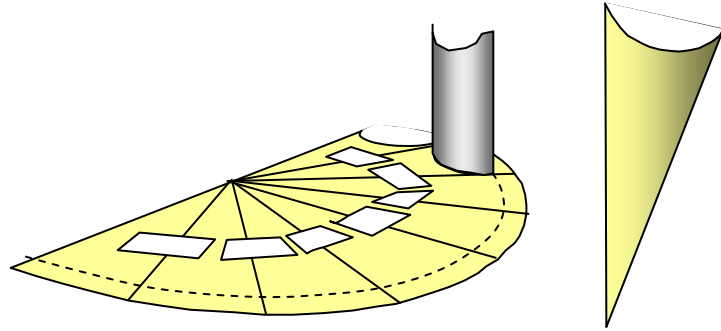

8. Using the same gouge cut some pieces from a contrasting veneer to fit into the scoops and hold these in place with more gummed veneer tape.

**Note:** Keep all of your veneer tape on the same side.

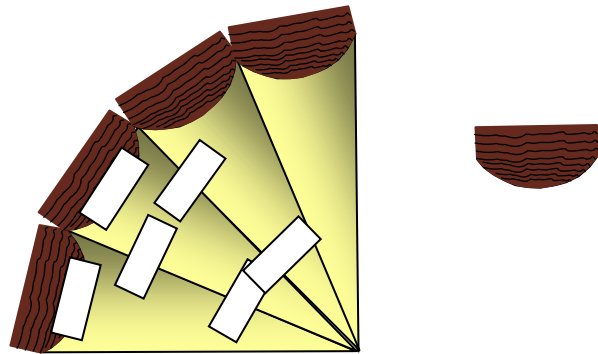

9. Once all of the infill pieces are taped in place glue the fan to a piece of paper or thin card. Trim off the excess material using a sharp knife and template remembering to take care for safety and accuracy.

**Note:** Check the accuracy of the points of the triangles. You may wish to chop another scallop at the base of your fan. **(See below right)**

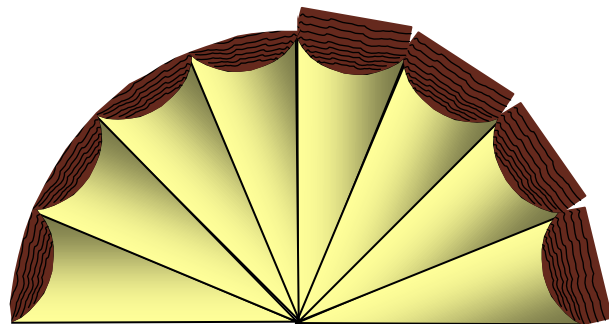

10. Your fan is now complete – keep it in a safe place in readiness to use in future furniture projects.

